



# **DS-KB8113-IME1(B) Series Vandal-Resistant Door Station**

**User Manual**

## Legal Information

### About this Manual

The Manual includes instructions for using and managing the Product. Pictures, charts, images and all other information hereinafter are for description and explanation only. The information contained in the Manual is subject to change, without notice, due to firmware updates or other reasons. Please find the latest version of this Manual at the company website Please use this Manual with the guidance and assistance of professionals trained in supporting the Product.

### Trademarks Acknowledgement

Trademarks and logos mentioned are the properties of their respective owners.

### LEGAL DISCLAIMER

TO THE MAXIMUM EXTENT PERMITTED BY APPLICABLE LAW, THIS MANUAL AND THE PRODUCT DESCRIBED, WITH ITS HARDWARE, SOFTWARE AND FIRMWARE, ARE PROVIDED "AS IS" AND "WITH ALL FAULTS AND ERRORS". OUR COMPANY MAKES NO WARRANTIES, EXPRESS OR IMPLIED, INCLUDING WITHOUT LIMITATION, MERCHANTABILITY, SATISFACTORY QUALITY, OR FITNESS FOR A PARTICULAR PURPOSE. THE USE OF THE PRODUCT BY YOU IS AT YOUR OWN RISK. IN NO EVENT WILL OUR COMPANY BE LIABLE TO YOU FOR ANY SPECIAL, CONSEQUENTIAL, INCIDENTAL, OR INDIRECT DAMAGES, INCLUDING, AMONG OTHERS, DAMAGES FOR LOSS OF BUSINESS PROFITS, BUSINESS INTERRUPTION, OR LOSS OF DATA, CORRUPTION OF SYSTEMS, OR LOSS OF DOCUMENTATION, WHETHER BASED ON BREACH OF CONTRACT, TORT (INCLUDING NEGLIGENCE), PRODUCT LIABILITY, OR OTHERWISE, IN CONNECTION WITH THE USE OF THE PRODUCT, EVEN IF OUR COMPANY HAS BEEN ADVISED OF THE POSSIBILITY OF SUCH DAMAGES OR LOSS.

YOU ACKNOWLEDGE THAT THE NATURE OF THE INTERNET PROVIDES FOR INHERENT SECURITY RISKS, AND OUR COMPANY SHALL NOT TAKE ANY RESPONSIBILITIES FOR ABNORMAL OPERATION, PRIVACY LEAKAGE OR OTHER DAMAGES RESULTING FROM CYBER-ATTACK, HACKER ATTACK, VIRUS INFECTION, OR OTHER INTERNET SECURITY RISKS; HOWEVER, OUR COMPANY WILL PROVIDE TIMELY TECHNICAL SUPPORT IF REQUIRED.

YOU AGREE TO USE THIS PRODUCT IN COMPLIANCE WITH ALL APPLICABLE LAWS, AND YOU ARE SOLELY RESPONSIBLE FOR ENSURING THAT YOUR USE CONFORMS TO THE APPLICABLE LAW. ESPECIALLY, YOU ARE RESPONSIBLE, FOR USING THIS PRODUCT IN A MANNER THAT DOES NOT INFRINGE ON THE RIGHTS OF THIRD PARTIES, INCLUDING WITHOUT LIMITATION, RIGHTS OF PUBLICITY, INTELLECTUAL PROPERTY RIGHTS, OR DATA PROTECTION AND OTHER PRIVACY RIGHTS. YOU SHALL NOT USE THIS PRODUCT FOR ANY PROHIBITED END-USES, INCLUDING THE DEVELOPMENT OR PRODUCTION OF WEAPONS OF MASS DESTRUCTION, THE DEVELOPMENT OR PRODUCTION OF CHEMICAL OR BIOLOGICAL WEAPONS, ANY ACTIVITIES IN THE CONTEXT RELATED TO ANY NUCLEAR EXPLOSIVE OR UNSAFE NUCLEAR FUEL-CYCLE, OR IN SUPPORT OF HUMAN RIGHTS ABUSES.

IN THE EVENT OF ANY CONFLICTS BETWEEN THIS MANUAL AND THE APPLICABLE LAW, THE LATER PREVAILS.



## **Data Protection**

During the use of device, personal data will be collected, stored and processed. To protect data, the development of our devices incorporates privacy by design principles. For example, for device with facial recognition features, biometrics data is stored in your device with encryption method; for fingerprint device, only fingerprint template will be saved, which is impossible to reconstruct a fingerprint image.

As data controller, you are advised to collect, store, process and transfer data in accordance with the applicable data protection laws and regulations, including without limitation, conducting security controls to safeguard personal data, such as, implementing reasonable administrative and physical security controls, conduct periodic reviews and assessments of the effectiveness of your security controls.

## Symbol Conventions

The symbols that may be found in this document are defined as follows.

Symbol	Description
 <b>Danger</b>	Indicates a hazardous situation which, if not avoided, will or could result in death or serious injury.
 <b>Caution</b>	Indicates a potentially hazardous situation which, if not avoided, could result in equipment damage, data loss, performance degradation, or unexpected results.
 <b>Note</b>	Provides additional information to emphasize or supplement important points of the main text.

## Safety Instruction

### Warning

- All the electronic operation should be strictly compliance with the electrical safety regulations, fire prevention regulations and other related regulations in your local region.
- Please use the power adapter, which is provided by normal company. The power consumption cannot be less than the required value.
- Do not connect several devices to one power adapter as adapter overload may cause over-heat or fire hazard.
- Please make sure that the power has been disconnected before you wire, install or dismantle the device.
- When the product is installed on wall or ceiling, the device shall be firmly fixed.
- If smoke, odors or noise rise from the device, turn off the power at once and unplug the power cable, and then please contact the service center.
- If the product does not work properly, please contact your dealer or the nearest service center. Never attempt to disassemble the device yourself. (We shall not assume any responsibility for problems caused by unauthorized repair or maintenance.)

### Caution

- Do not drop the device or subject it to physical shock, and do not expose it to high electromagnetism radiation. Avoid the equipment installation on vibrations surface or places subject to shock (ignorance can cause equipment damage).
- Do not place the device in extremely hot (refer to the specification of the device for the detailed operating temperature), cold, dusty or damp locations, and do not expose it to high electromagnetic radiation.
- The device cover for indoor use shall be kept from rain and moisture.
- Exposing the equipment to direct sun light, low ventilation or heat source such as heater or radiator is forbidden (ignorance can cause fire danger).
- Do not aim the device at the sun or extra bright places. A blooming or smear may occur otherwise (which is not a malfunction however), and affecting the endurance of sensor at the same time.
- Please use the provided glove when open up the device cover, avoid direct contact with the device cover, because the acidic sweat of the fingers may erode the surface coating of the device cover.
- Please use a soft and dry cloth when clean inside and outside surfaces of the device cover, do not use alkaline detergents.
- Please keep all wrappers after unpack them for future use. In case of any failure occurred, you need to return the device to the factory with the original wrapper. Transportation without the original wrapper may result in damage on the device and lead to additional costs.

- Improper use or replacement of the battery may result in hazard of explosion. Replace with the same or equivalent type only. Dispose of used batteries according to the instructions provided by the battery manufacturer.
- Improper replacement of the battery with an incorrect type may defeat a safeguard (for example, in case of some lithium battery types).
- Do not dispose of the battery into fire or a hot oven, or mechanically crush or cut the battery, which may result in an explosion.
- Do not leave the battery in an extremely high temperature surrounding environment, which may result in an explosion or leakage of flammable liquid or gas.
- Do not subject the battery to extremely low air pressure, which may result in an explosion or the leakage of flammable liquid or gas.
- CAUTION: Risk of explosion if the battery is replaced by an incorrect type.

## Regulatory Information

### FCC Information

Please take attention that changes or modification not expressly approved by the party responsible for compliance could void the user's authority to operate the equipment.

FCC compliance: This equipment has been tested and found to comply with the limits for a Class B digital device, pursuant to part 15 of the FCC Rules. These limits are designed to provide reasonable protection against harmful interference in a residential installation. This equipment generates, uses and can radiate radio frequency energy and, if not installed and used in accordance with the instructions, may cause harmful interference to radio communications. However, there is no guarantee that interference will not occur in a particular installation. If this equipment does cause harmful interference to radio or television reception, which can be determined by turning the equipment off and on, the user is encouraged to try to correct the interference by one or more of the following measures:

- Reorient or relocate the receiving antenna.
- Increase the separation between the equipment and receiver.
- Connect the equipment into an outlet on a circuit different from that to which the receiver is connected.
- Consult the dealer or an experienced radio/TV technician for help

This equipment should be installed and operated with a minimum distance 20cm between the radiator and your body.

#### FCC Conditions

This device complies with part 15 of the FCC Rules. Operation is subject to the following two conditions:

1. This device may not cause harmful interference.
2. This device must accept any interference received, including interference that may cause undesired operation.

### EU Conformity Statement



This product and - if applicable - the supplied accessories too are marked with "CE" and comply therefore with the applicable harmonized European standards listed

under the EMC Directive 2014/30/EU, RE Directive 2014/53/EU, the RoHS Directive 2011/65/EU



2012/19/EU (WEEE directive): Products marked with this symbol cannot be disposed of as unsorted municipal waste in the European Union. For proper recycling, return this product to your local supplier upon the purchase of equivalent new equipment, or dispose of it at designated collection points. For more information see: [www.recyclethis.info](http://www.recyclethis.info)



2006/66/EC (battery directive): This product contains a battery that cannot be disposed of as unsorted municipal waste in the European Union. See the product documentation for specific battery information. The battery is marked with this symbol, which may include lettering to indicate cadmium (Cd), lead (Pb), or mercury (Hg). For proper recycling, return the battery to your supplier or to a designated collection point. For more information see: [www.recyclethis.info](http://www.recyclethis.info)

### Industry Canada ICES-003 Compliance

This device meets the CAN ICES-3 (B)/NMB-3(B) standards requirements.

This device complies with Industry Canada licence-exempt RSS standard(s). Operation is subject to the following two conditions:

1. this device may not cause interference, and
2. this device must accept any interference, including interference that may cause undesired operation of the device.

Le présent appareil est conforme aux CNR d'Industrie Canada applicables aux appareils radioexempts de licence. L'exploitation est autorisée aux deux conditions suivantes :

1. l'appareil ne doit pas produire de brouillage, et
2. l'utilisateur de l'appareil doit accepter tout brouillage radioélectrique subi, même si le brouillage est susceptible d'en compromettre le fonctionnement.

Under Industry Canada regulations, this radio transmitter may only operate using an antenna of a type and maximum (or lesser) gain approved for the transmitter by Industry Canada. To reduce potential radio interference to other users, the antenna type and its gain should be so chosen that the equivalent isotropically radiated power (e.i.r.p.) is not more than that necessary for successful communication.

Conformément à la réglementation d'Industrie Canada, le présent émetteur radio peut fonctionner avec une antenne d'un type et d'un gain maximal (ou inférieur) approuvé pour l'émetteur par Industrie Canada. Dans le but de réduire les risques de brouillage radioélectrique à l'intention des autres utilisateurs, il faut choisir le type d'antenne et son gain de sorte que la puissance isotrope rayonnée équivalente (p.i.r.e.) ne dépasse pas l'intensité nécessaire à l'établissement d'une communication satisfaisante.

This equipment should be installed and operated with a minimum distance 20cm between the radiator and your body.

Cet équipement doit être installé et utilisé à une distance minimale de 20 cm entre le radiateur et votre corps.

# Contents

<b>Chapter 1 Appearance .....</b>	<b>1</b>
<b>Chapter 2 Terminal and Wiring Description .....</b>	<b>3</b>
2.1 Terminal Description .....	3
2.2 Wiring Description .....	4
2.2.1 Door Lock Wiring .....	4
2.2.2 Door Contact Wiring .....	5
2.2.3 Exit Button Wiring .....	5
2.2.4 Alarm Device Input Wiring .....	7
<b>Chapter 3 Door Station Installation .....</b>	<b>8</b>
3.1 Wall Mounting Plate .....	8
3.2 Wall Mounting .....	8
<b>Chapter 4 Activate Device via Web .....</b>	<b>14</b>
<b>Chapter 5 Remote Configuration via Indoor Station .....</b>	<b>15</b>
5.1 Set Up Door Station via Indoor Station .....	15
5.2 Local Operation .....	15
<b>Chapter 6 Remote Configuration via Mobile Client .....</b>	<b>17</b>
6.1 Set Up Mobile Client .....	17
6.2 Set Up Door Station via Client .....	17
6.3 Remote Operation via Client .....	18
<b>Chapter 7 Remote Configuration via Web .....</b>	<b>22</b>
7.1 Live View .....	22
7.2 User Management .....	22
7.3 Device Management .....	23
7.4 Configuration .....	24
7.4.1 Local Parameters Settings .....	24
7.4.2 System Settings .....	25

7.4.3 Network Settings .....	27
7.4.4 Video & Audio Settings .....	31
7.4.5 Image Settings .....	35
7.4.6 Event Settings .....	38
7.4.7 Intercom Settings .....	42
7.4.8 Access Control Settings .....	45
<b>Appendix A. Appendix .....</b>	<b>47</b>

## Chapter 1 Appearance

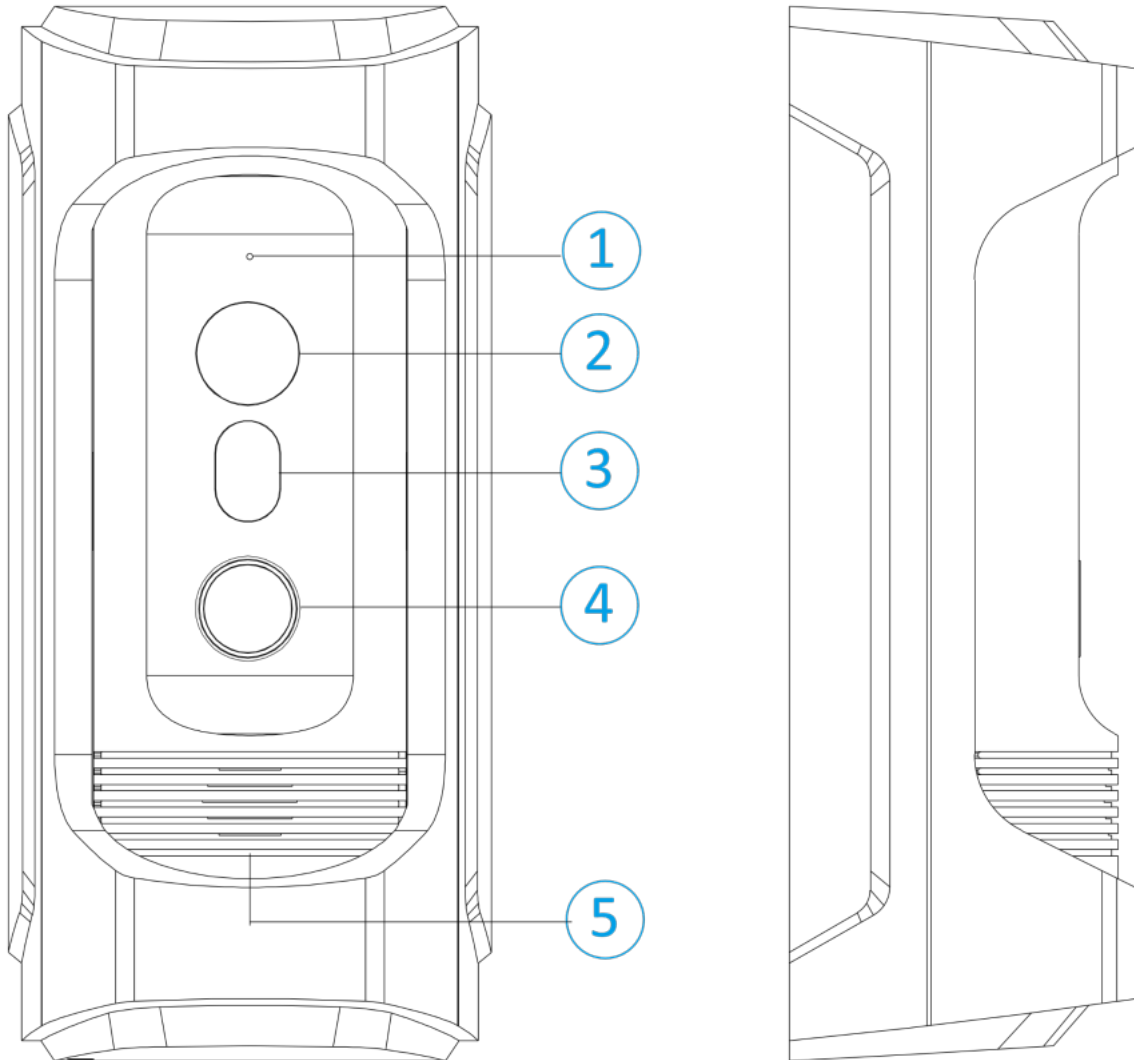

Figure 1-1 Appearance

Table 1-1 Component Description

No.	Description
1	Microphone
2	Built-in Camera
3	Low Illumination Supplement Light

No.	Description
4	Call Button
5	Loudspeaker

## Chapter 2 Terminal and Wiring Description

### 2.1 Terminal Description

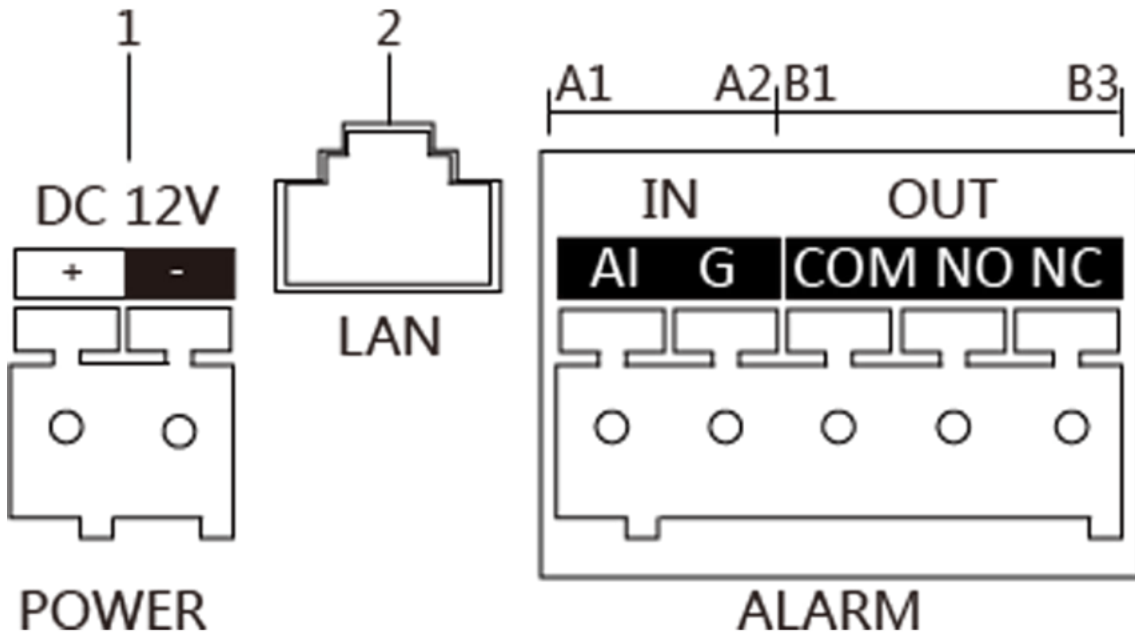

Figure 2-1 Terminals Description

Table 2-1 Description

Name	No.	Interface	Description
Power Supply	1	12 VDC	12 VDC Power Supply Input
LAN	2	LAN	Network Interface (PoE Supported)
ALARM IN	A1	AI	Alarm Input
	A2	GND	Grounding
ALARM OUT	B1	COM	Common Interface
	B2	NO	Door Lock Relay Output (Connect Electric Strike)
	B3	NC	Door Lock Relay Output (Connect Electric Bolt or Contact Lock)

## 2.2 Wiring Description

### 2.2.1 Door Lock Wiring

Terminal NC/COM is set as default for connecting magnetic lock/electric bolt; terminal NO/ COM is set as default for connecting electric strike.

To connect electric lock, it is required to set the output of terminal NC/COM/NO to be electric lock via Batch Configuration Tool or **Guarding Vision** client software or the web browser.

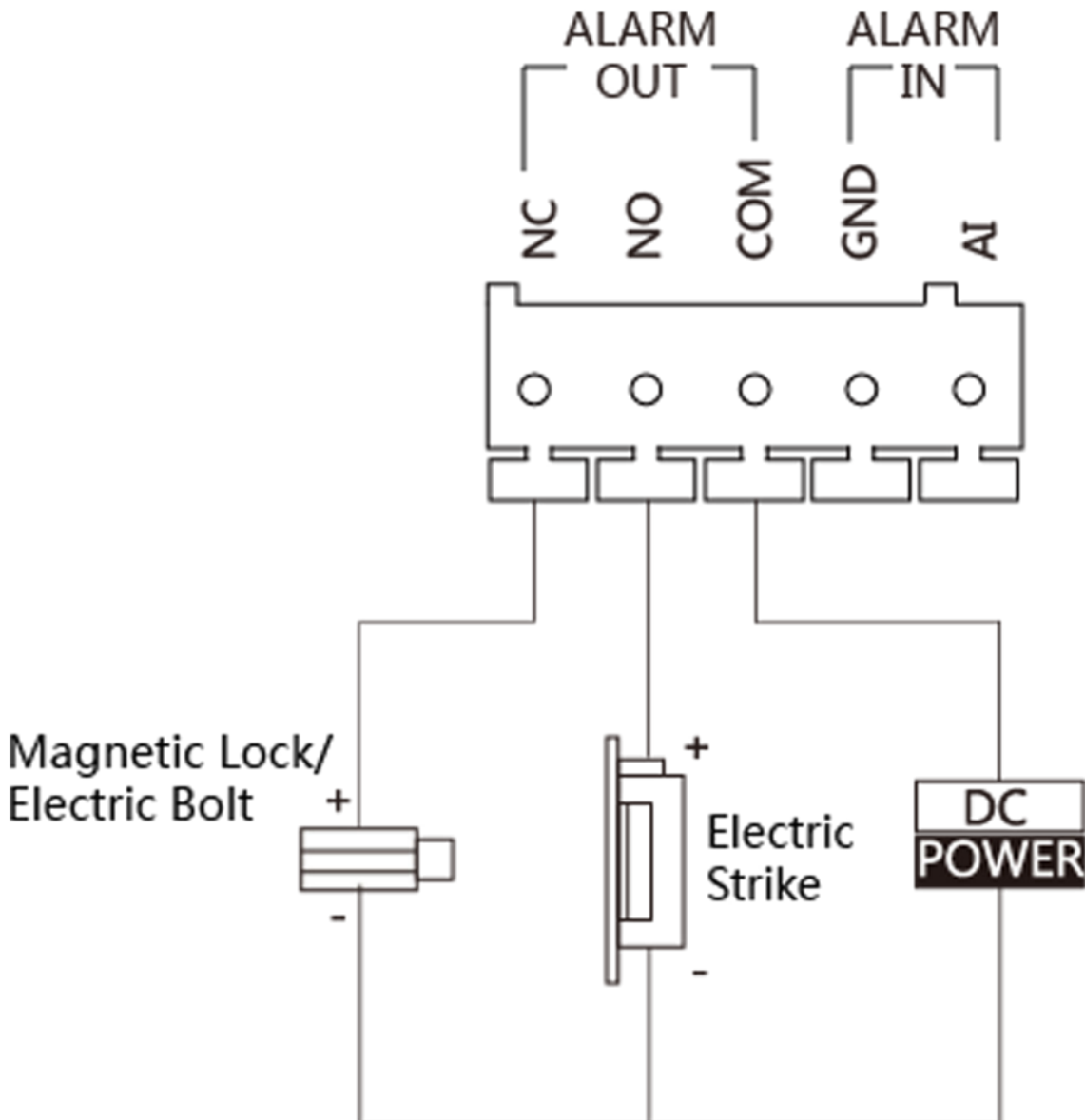

Figure 2-2 Door Lock Wiring

### 2.2.2 Door Contact Wiring

To connect door contact, it is required to set the output of terminal AI to be door status via Batch Configuration Tool or **Guarding Vision** client software or the web browser.

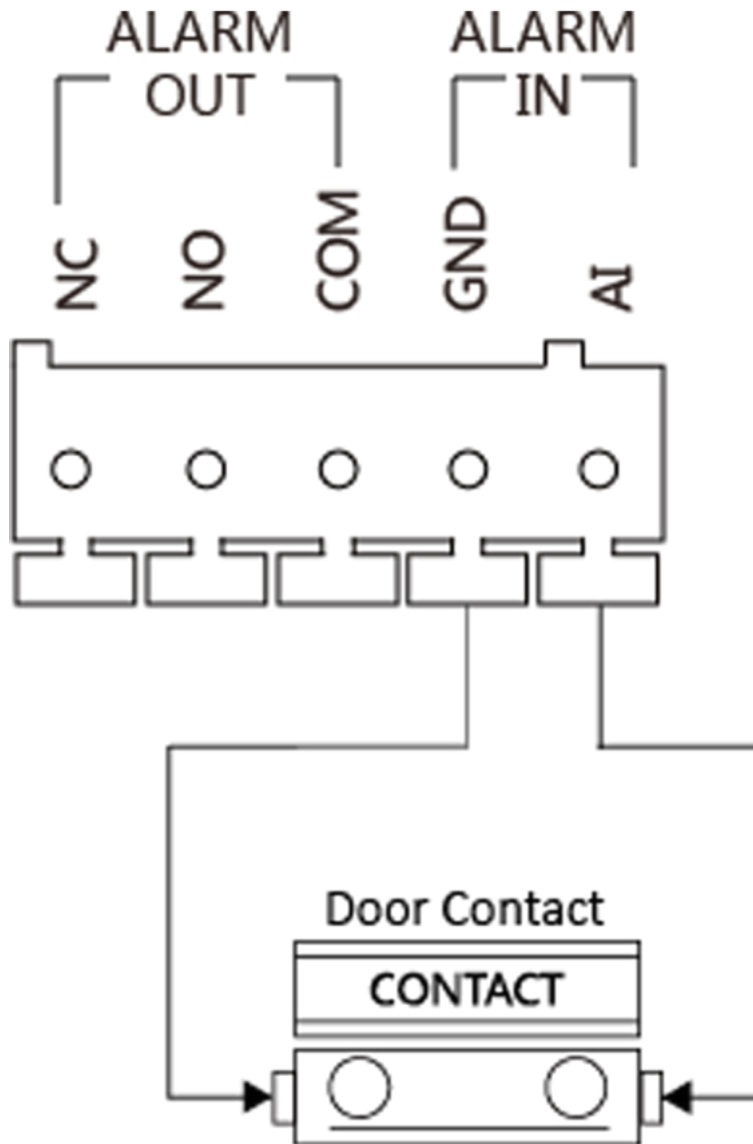

Figure 2-3 Door Contact Wiring

### 2.2.3 Exit Button Wiring

To connect exit button, it is required to set the output of terminal AI to be door status via Batch Configuration Tool or **Guarding Vision** client software or the web browser.

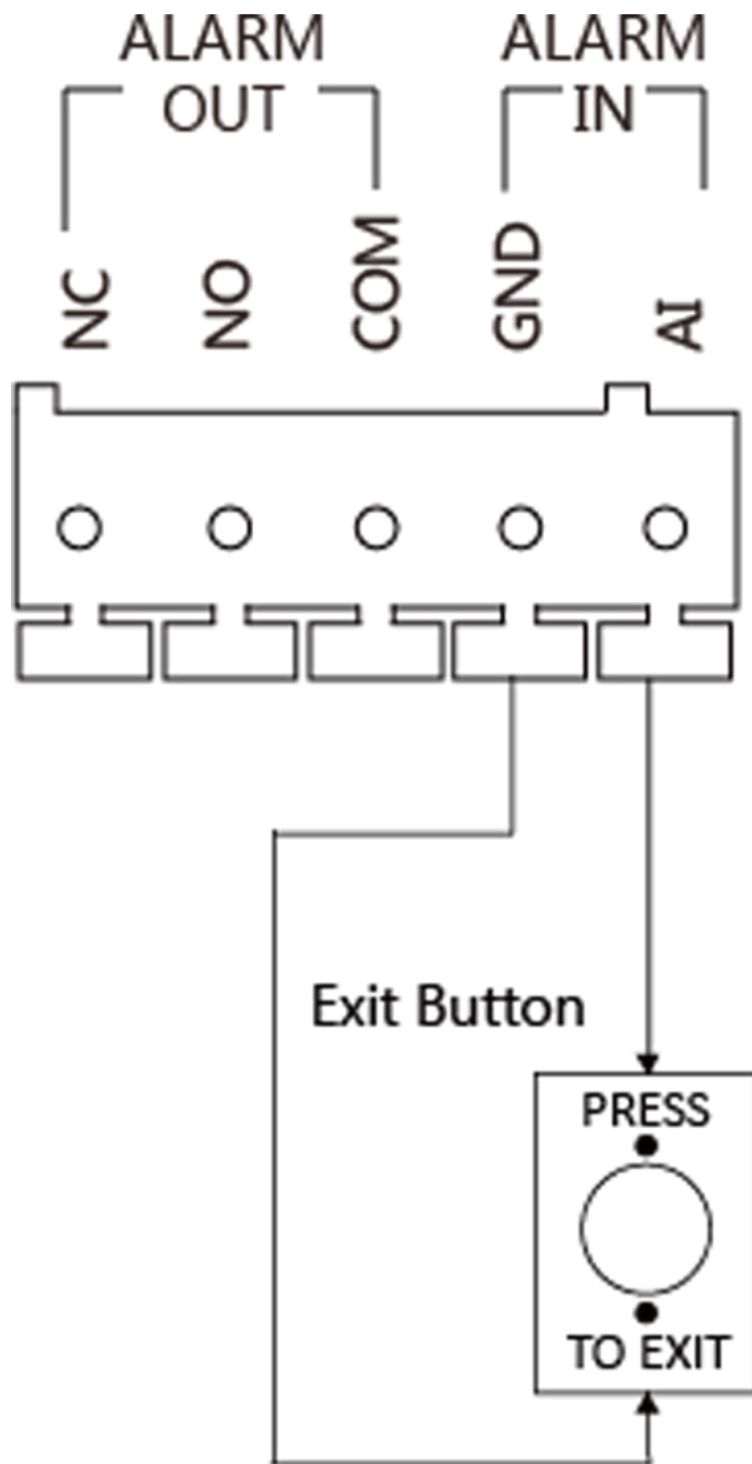

Figure 2-4 Exit Button Wiring

### 2.2.4 Alarm Device Input Wiring

When you set the output of terminal AI to be custom via Batch Configuration Tool or **Guarding Vision** client software or the web browser, you can connect any alarm input device to the door station via the terminal AI.

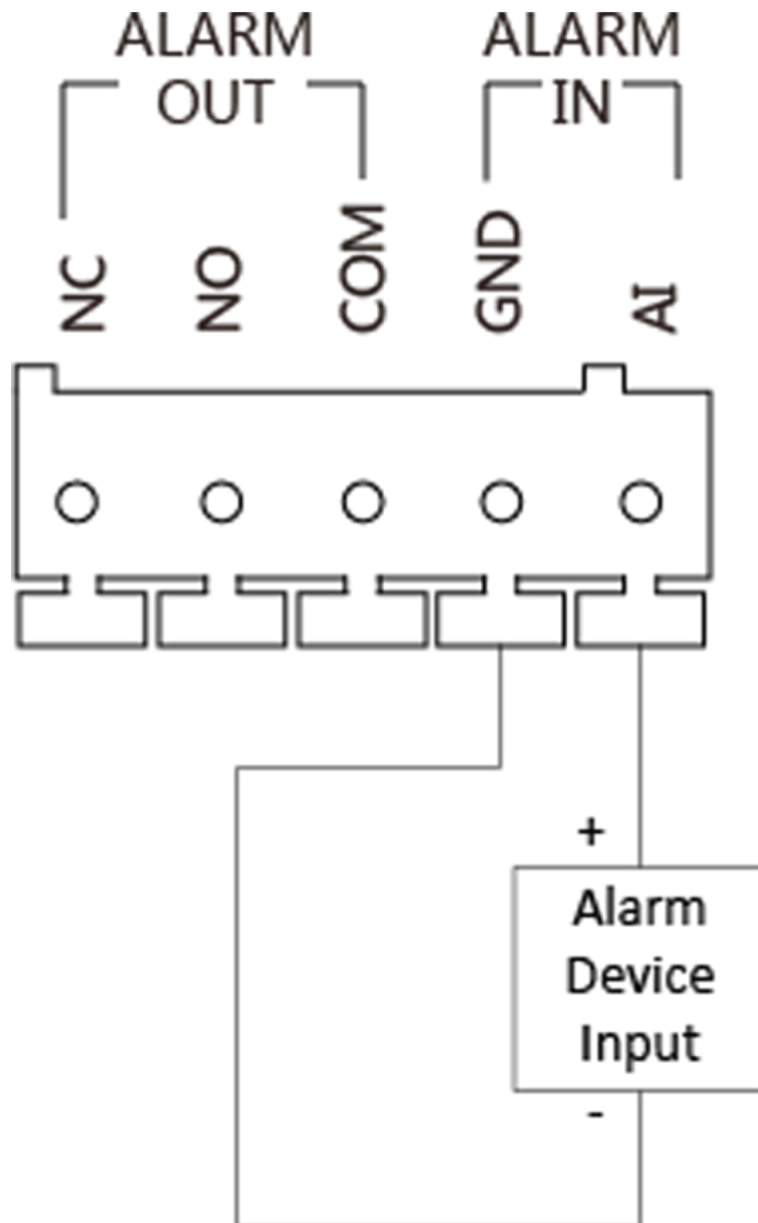

Figure 2-5 Alarm Device Input Wiring

## Chapter 3 Door Station Installation

### 3.1 Wall Mounting Plate

To install the door station onto the wall, you are required to use a matched mounting plate.

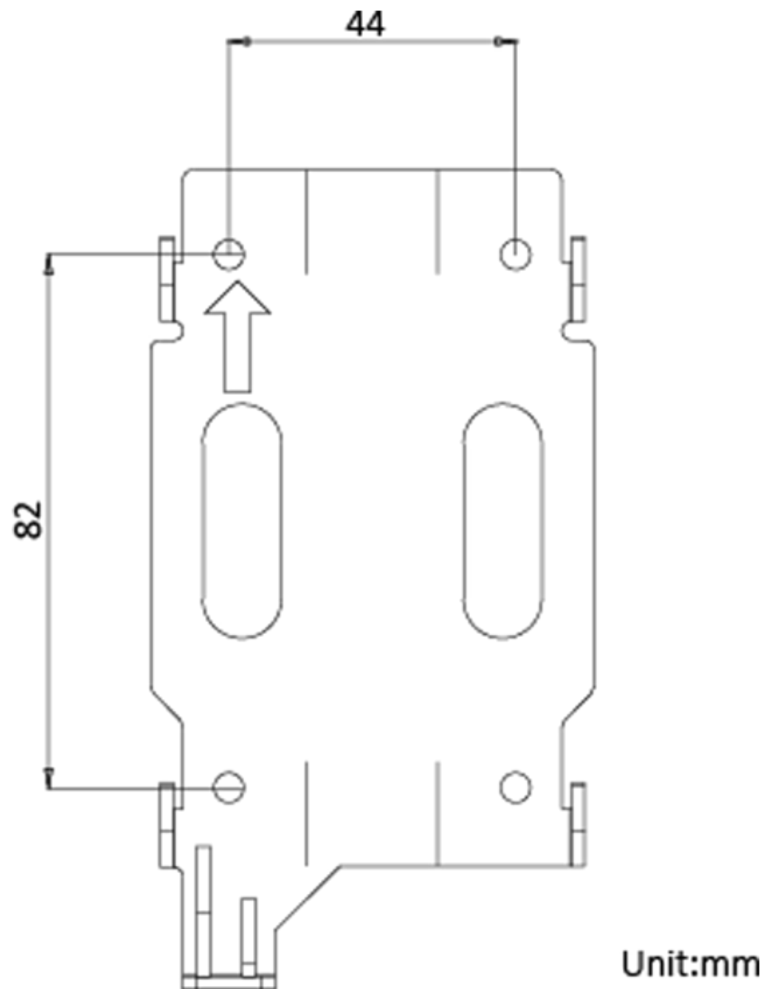
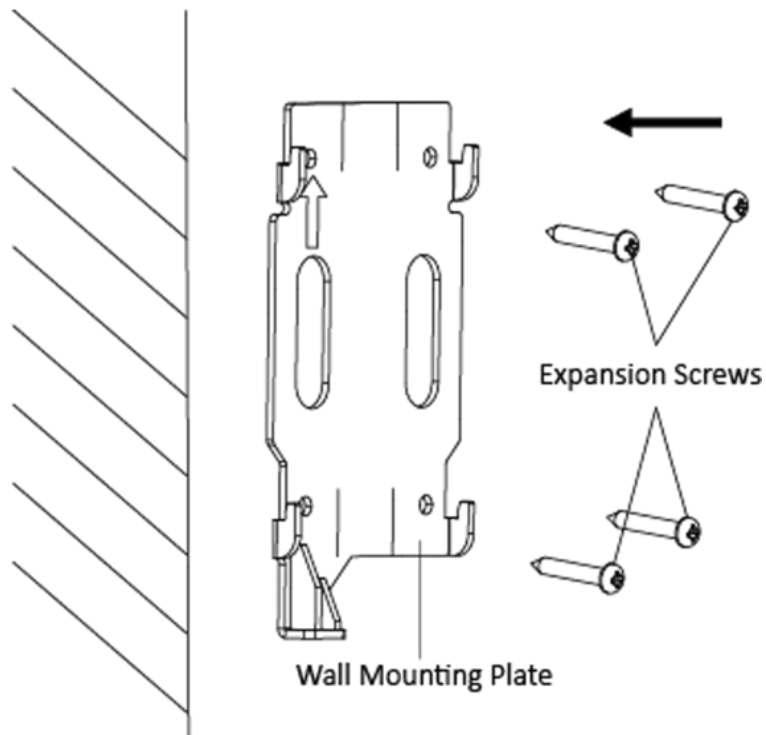

Figure 3-1 Wall Mounting Plate

### 3.2 Wall Mounting

#### Steps

1. Fix the wall mounting plate to the wall with 4 expansion screws.



**Figure 3-2 Install the Plate**

2. Insert terminal blocks into the interfaces of the door station body, and connect the network cable.

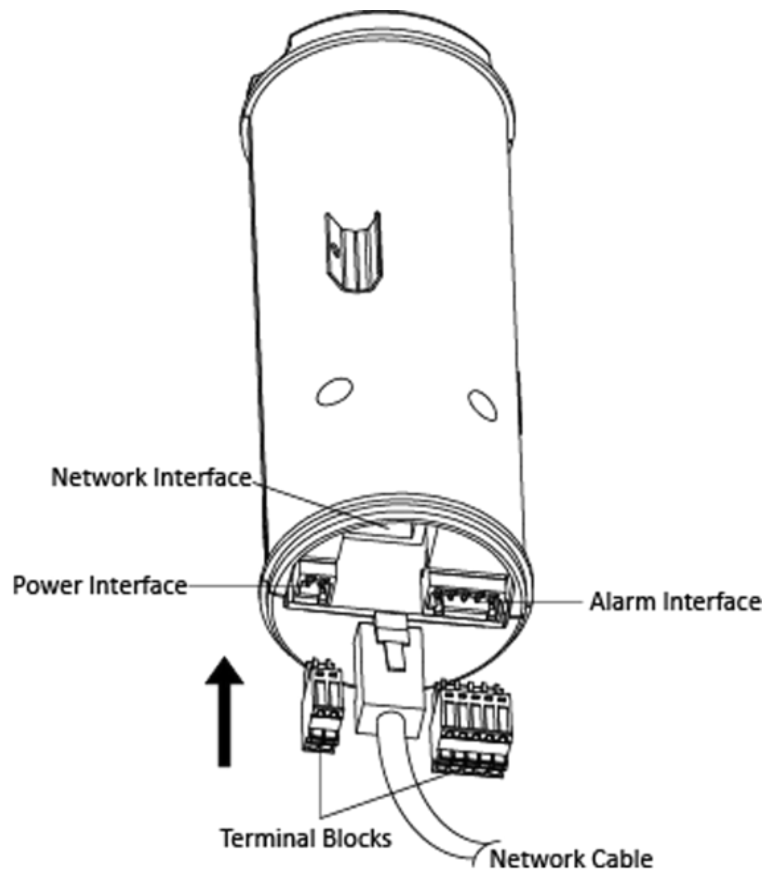

**Figure 3-3 Insert Terminals and Network Cable**

3. Fix the door station body to the protective shield tightly.

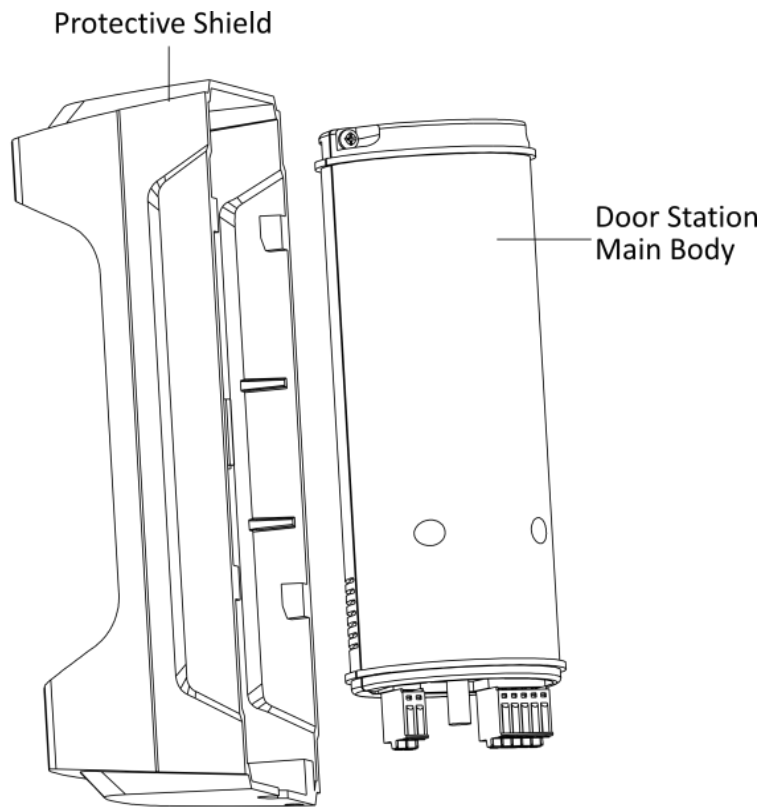

**Figure 3-4 Fix the Body to the Shield**

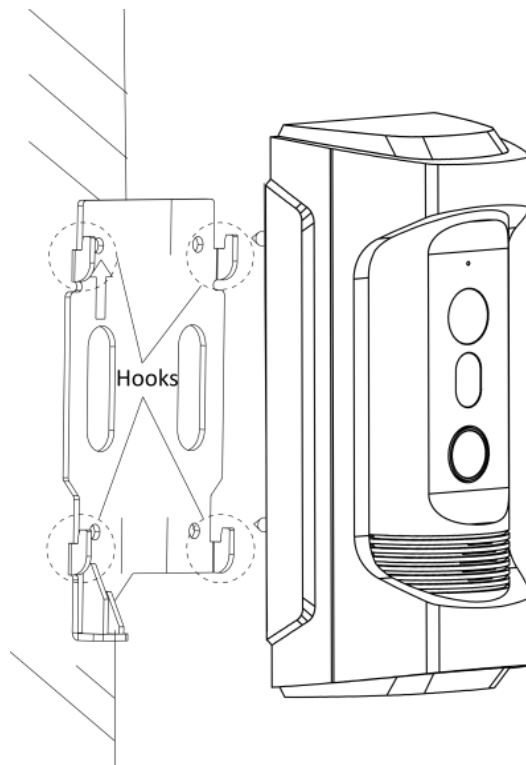

4. Hook the door station to the wall mounting plate tightly.

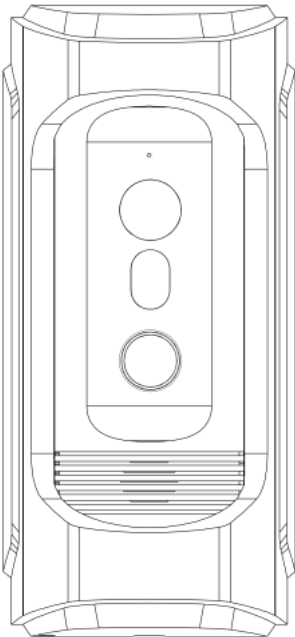

**Figure 3-5 Hook the Door Station to the Plate**

5. Use the set screw to secure the door station with the mounting plate.



-  Set Screw
-  Rubber Plug

**Figure 3-6 Secure the Door Station**

## Chapter 4 Activate Device via Web

You are required to activate the device first by setting a strong password for it before you can use the device.

Default parameters of the door station are as follows:

- Default IP Address: 192.0.0.65.
- Default Port No.: 8000.
- Default User Name: admin.

### Steps

1. Power on the device, and connect the device to the network.
2. Enter the IP address into the address bar of the web browser, and click **Enter** to enter the activation page.



### Note

The computer and the device should belong to the same subnet.

---

3. Create and enter a password into the password field.
4. Confirm the password.
5. Click **OK** to activate the device.

## Chapter 5 Remote Configuration via Indoor Station

### 5.1 Set Up Door Station via Indoor Station

#### Steps

1. Choose Language and tap **Next**.
2. Set network parameters and tap **Next**
  - Edit **Local IP**, **Subnet Mask** and **Gateway** parameters.
  - Enable **DHCP**, the device will get network parameters automatically.
3. Configure the indoor station.
  - 1) Choose **Indoor Station Type**.
  - 2) Edit **Floor** and **Room No.**
  - 3) Tap **Next**.
4. Linked related devices and tap **Next**. If the device and the indoor station are in the same LAN, the device will be displayed in the list. Tap the device or enter the serial No. to link.
  - 1) Tap the door station in the list to link.



If the door station is inactive, the system will pop up the dialog to activate the door station.

- 2) Tap  to pop up the Network Settings page.
  - 3) Edit the network parameters of the door station manually or enable **DHCP** to get the network parameters automatically.
  - 4) **Optional:** Enable **Synchronize Language** to synchronize the language of door station with indoor station.
  - 5) Tap **OK** to save the settings.
5. Tap **Finish** to save the settings.

### 5.2 Local Operation

You can call the resident (the indoor station) or the center (the master station) via the door station by pressing or holding the call button. Default settings of the call button: when you press the call button, it calls the resident, and when you hold the call button, it calls the center.

#### Before You Start

- Make sure the door station has been activated.
- Make sure the network cable is well-connected.

#### Steps

1. Press the call button to call the resident.
2. The resident can accept/decline the calling from the door station, and unlock the door via the indoor station.



### Note

- Besides the indoor station, you can also unlock the door by the master station, the client software, and the web.
  - When the video intercom between you and the resident is realized, you can speak to the resident, and the live view of door station will be displayed on the connected indoor station.
  - When live view of door station is displayed on other devices or door station is calling resident, the door station will detect the brightness of video. When the brightness is lower than the expected threshold, the supplement light will be enabled.
  - When the supplement light is enabled, the backlight of key will be auto-enabled, otherwise, the door station will detect the brightness of live view and enable the backlight of key when the brightness of live view is lower than expected threshold.
-

## Chapter 6 Remote Configuration via Mobile Client

### 6.1 Set Up Mobile Client

#### Before You Start

Make sure your mobile device has been connected to Wi-Fi.

Guarding Vision client is necessary for door station configuration and operation.

#### Steps

1. Install **Guarding Vision** client and register a user account for iOS and Android.
  - 1) Search **Guarding Vision** in App Store or Google Play™ to download and install the client.
  - 2) Launch the App and follow the on-screen instructions to register a user account.
2. Start the **Guarding Vision** client, and login the client.

### 6.2 Set Up Door Station via Client



To operate the door station normally, you should add the door station to the client.

#### Steps

1. On the home page of the client, tap **Add Device**.

- Scan QR code of the device to add.
- 

#### Note

- The QR code is printed on the label, which is on the rear panel of door station. If you have already installed the device, you can scan the QR code on the cloud service page in the device.
  - Tap  to enable the flashlight if the scanning environment is too dark.
- 
- If there are device QR codes in photo album of the phone, tap  extract QR code from local album.
  - If the system fails to recognize the QR code, tap  and enter the serial No. to add the device manually.

2. Connect to the network.

- 1) Tap **Next**.
  - 2) Connect the device to the router with a network cable.
- 

#### Note

Make sure your mobile phone is connected to the same router.

---

- 3) Tap **Connected**.

3. The account is connected to the device.

## 6.3 Remote Operation via Client

You can realize some certain functions of the door station via **Guarding Vision** (including, but not limited to, live view, and remote playback).

### Live View

Tap the door station in the list to open the floating windows. And then tap the floating window to enter the Live View page.

Tap the video on the screen, you can tap  to capture the screen.

Tap  to record.

### Two-Way Audio

Call from client software: On the Live View page, tap  to create a call between the client and the device.

Receive call from the device: You can receive or decline the call from device.

Tap  to receive the call.

Tap  to decline the call.

Tap  to unlock the door remotely.

Tap  to adjust the volume.

When you communication with the device, you can tap  to mute.

### Unlock Remotely

On the main page or on the live view page, tap  to unlock the door.

### Playback

On the Live View page, tap ... → **Playback** to playback the videos stored in the TF card.

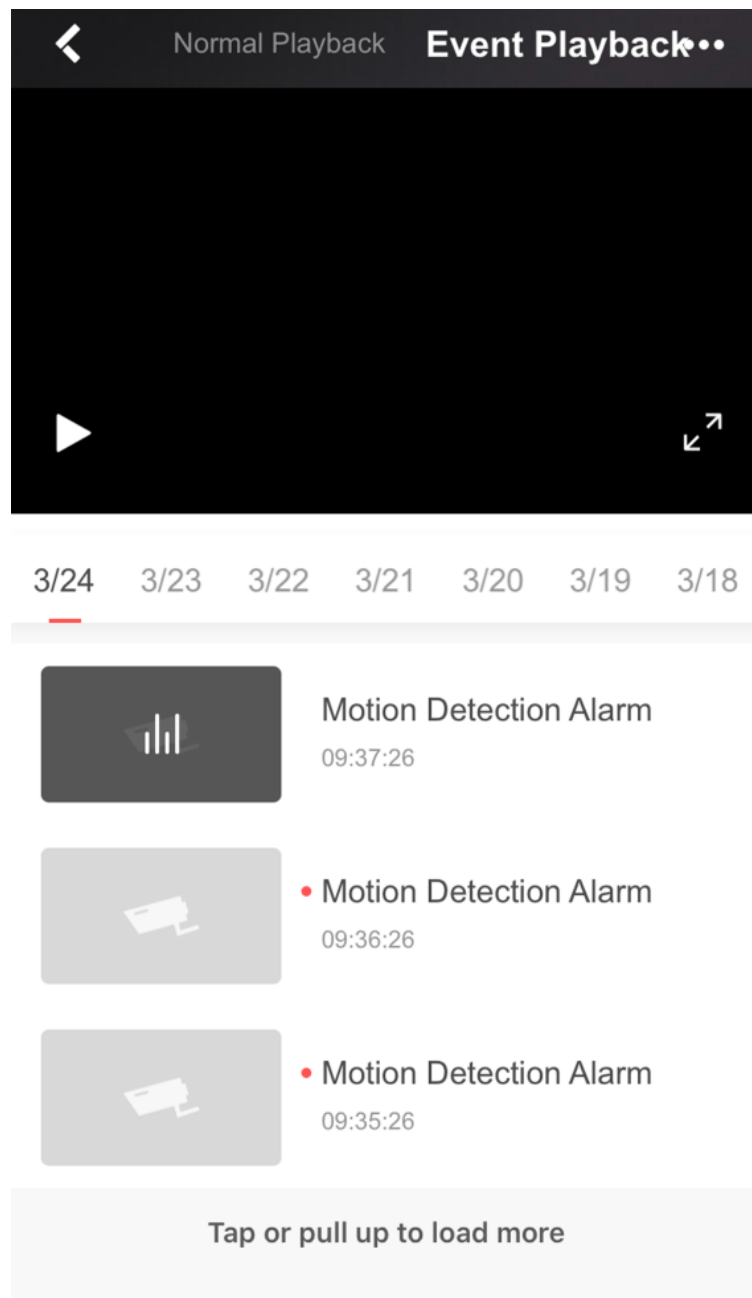

Figure 6-1 Playback

### Synchronize Time

On the Live View page, tap ... → **Settings**, you can set the time of door station.  
Tap **Time Zone** to select the right time zone.  
Tap **Date Format** to change the format.

## Alarm Notification

On the Live View page, tap ... → **Settings** → **Notification** , slide the slider to enable alarm notification.

Tap **Draw Motion Detection Area** and select area. Tap  to save.

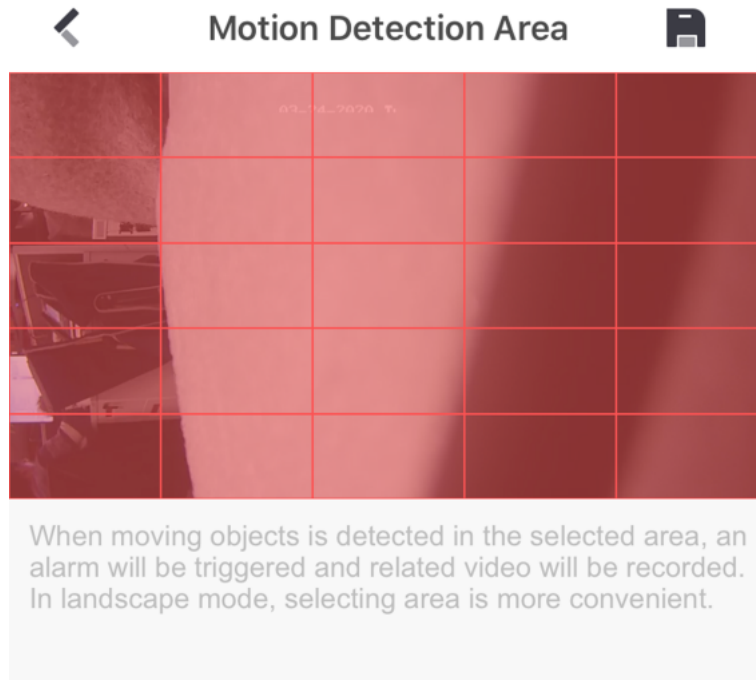

**Figure 6-2 Draw Motion Detection Area**

Tap **Motion Detection Sensitivity** to adjust the sensitivity.

---

### Note

When **Motion Detection** is triggered, the device can capture the picture and upload to the platform as an event.

---

## Volume

On the Live View page, tap ... → **Settings** , you can adjust the **Loudspeaker Volume** and **Microphone Volume**.

---

### Note

Loudspeaker volume and microphone volume can be set from 0 to 10.

---

## Notification



On the home page of the client, tap **Notification** to get or edit alarm messages.

---

### **Note**

- The messages will be pushed automatically by enabling Receive Events and Push Notifications.
  - The client can receive the triggered alarm automatically when the door station is powered on by Receive Events but NOT Push Notifications.
- 

### **Share Account**

On the main page, tap  to share the information to other accounts. Or on the live view page, tap ...  **Share** to share.

---

### **Note**

Up to 4 accounts can be added to share.

---

## Chapter 7 Remote Configuration via Web

### 7.1 Live View

In the browser address bar, enter the IP address of the device, and press the Enter key to enter the login page.

Enter the user name and password and click **Login** to enter the Live View page. Or you can click **Live View** to enter the page.

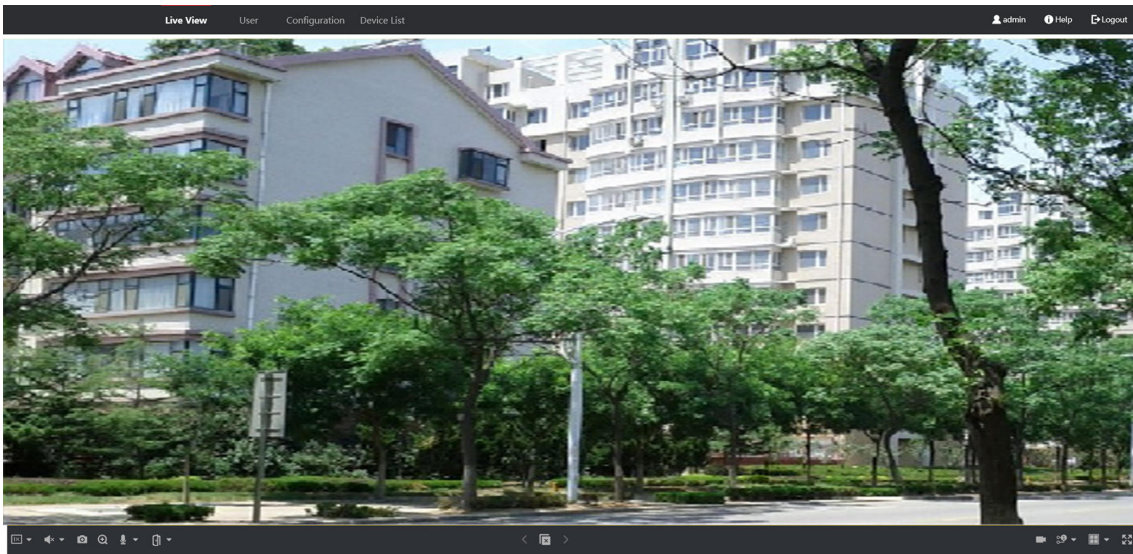

Figure 7-1 Live View

- You can start/stop live view, capture, record, audio on/off, two-way audio, etc.
- The stream type can be set as main stream or sub stream.
- For IE (Internet Explorer) or Google users, the device support two-way audio communication.

---

#### Note

Live View function may vary with different models. Please refer to the actual product.

---

### 7.2 User Management

You can add, delete or search the information of the user.

Click **User** to enter the settings page.

#### **Add User**

## Basic Information

- Click **Add** to add users. Enter the **Employee ID, Name, Floor No.** and **Room No.**, Set the **Start Time** and **End Time**. You can set the user as **Administrator**.



If you disable **Always Valid**, setting start time and end time is necessary.

---

## Other Operation

- Click to modify the information of the user.
- Check the box of the user and click **Delete** to delete the selected user.
- Enter the keyword and click search icon. The information will display in the list.



User management function may vary with different models. Please refer to the actual product.

---

## 7.3 Device Management

You can manage the linked device on the page.

Click **Device Management** to enter the settings page.

### Add Device

- Click **Add** to add the indoor station, sub door station or decoder station. Enter the parameters and click **OK** to add.
- Click **Import**. Enter the information of the device in the template to import devices in batch.

### Export

Click **Export** to export the information to the PC.

### Delete

Select the device and click **Delete** to remove the selected device from the list.

### Refresh

Click **Refresh** to get the device information.

### Optional: Set device information.

- Click to edit device information.
- Click to delete device information from the list.
- Select **Status** and **Device Type** to search devices.

## 7.4 Configuration

### 7.4.1 Local Parameters Settings

You can configure the parameters of the live view, record files and captured pictures. The record files and captured pictures are the ones you record and capture by using the web browser. You can also set and view the saving paths of the captured pictures and recorded videos on the PC that running the web browser.

**Live View Parameters**

Stream Type  Main Stream  Sub-stream

Play Performance  Shortest Delay  Balanced  Fluent

Auto Start Live View  Yes  No

Image Format  JPEG  BMP

**Record File Settings**

Record File Size  256M  512M  1G

Save record files to

**Picture and Clip Settings**

Save snapshots in live view to

Figure 7-2 Local Parameters

#### Live View Parameters

##### Stream Type

Set the stream type as **Main Stream** or **Sub-stream**.

##### Play Performance

Set the live view performance to **Shortest Delay**, **Balanced** or **Fluent**.

##### Auto Start Live View

Check **Yes** to enable the function.

##### Image Format

Select the image format for picture capture.

Click **Save** to enable the settings.

### Record File Parameters

#### Record File Size

Select the packed size of the manually recorded and downloaded video files to **256M**, **512M** or **1G**. After the selection, the maximum record file size is the value you selected.

#### Save record files to

Set the saving path for the manually recorded video files.

Click **Save** to enable the settings.

### Picture and Clip Settings

#### Save snapshots in live view to

Set the saving path of the manually captured pictures in live view mode.



#### Note

You can click **Browse** to change the directory for saving the clips and pictures, and click **Open** to open the set folder of clips and picture saving.

---

Click **Save** to enable the settings.

## 7.4.2 System Settings

Follow the instructions below to configure the system settings, include System Settings, Maintenance, Security, and User Management, etc.

Click **System** to enter the settings page.

### Basic Information

Click **System Settings** → **Basic Information** to enter the settings page. On the page, you can edit **Device Name** and **Device No.** Set the **Language** according to your needs.

You can view the quantities of added users in **Capacity**.

Click **Save** to enable the settings.

### Time Settings

Click **System Settings** → **Time Settings** to enter the settings page. Select the **Time Zone** of your location from the drop-down list.

- Enable **NTP**, set the **Alarm Receiver Type**, **Server Address**, **NTP Port** and **Interval**.
- Enable **Manual Time Sync.**, set the time manually or check the **Sync. with computer time**.

Click **Save** to enable the settings.

## DST

Click **System Settings** → **DST** to check **Enable DST**. Set the parameters according to your needs and click **Save** to enable the settings.

## About

Click **System Settings** → **About** and click **Open Source Software Licenses** to view the details.

## Maintenance

Click **Maintenance** → **Upgrade & Maintenance** to enter the settings page.

- Reboot: Click **Reboot** to reboot the device.
- **Default**

Click **Default** to reset all the parameters, except the IP parameters and user information, to the default settings.

### Restore All

Click **Restore All** to restore all parameters to default settings.

- Unlink APP Account: Click **Unlink APP Account** to unlink the APP account of the device.
- Export parameters:
  1. Select **Device Parameters**, and click **Export** to pop up the dialog box.
  2. Set and confirm the encryption password.
  3. Click **OK** to export parameters.
- Import Config. File:
  1. Click browse icon to select the configuration file.
  2. Click **Import** and enter the encryption password to import.
- Upgrade: Click browse icon to select the upgrade file.



### Note

The upgrading process will last 1 to 10 minutes, do not power off during the upgrading. The device reboots automatically after upgrading.

---

## Security Service

Click **Security** → **Security Service** to enter the settings page. On the page, you can enable SSH according to your actual needs.

Click **Save** to enable the settings.

## User Management

Click **User Management** to enter the settings page.

Administrator can edit the permission for the users.

## Note

We highly recommend you to create a strong password of your own choosing (using a minimum of 8 characters, including at least three kinds of following categories: upper case letters, lower case letters, numbers, and special characters) in order to increase the security of your product. And we recommend you change your password regularly, especially in the high security system, changing the password monthly or weekly can better protect your product.

---

## Online Users

Click **User Management** → **Online Users** to enter the page.

Click **Refresh** to get the present information.

## Arming/Disarming Information

Click **User Management** → **Arming/Disarming Information** to view the information. Click **Refresh** to get the present information.

## 7.4.3 Network Settings

### TCP/IP Settings

TCP/IP settings must be properly configured before you operate the device over network. The device supports IPv4.

#### Steps

1. Click **Network** → **Basic Settings** → **TCP/IP** to enter the settings page.
2. Configure the network parameters.
  - Check **DHCP**, the device will get the parameters automatically.
  - Set the **IPv4 Address**, **IPv4 Subnet Mask** and **IPv4 Default Gateway** manually.
3. Select **Network Card**.
4. Configure the DNS server.
5. Click **Save** to enable the settings.

### Port Settings

#### Steps

1. Click **Network** → **Basic Settings** → **Port** to enter the settings page.

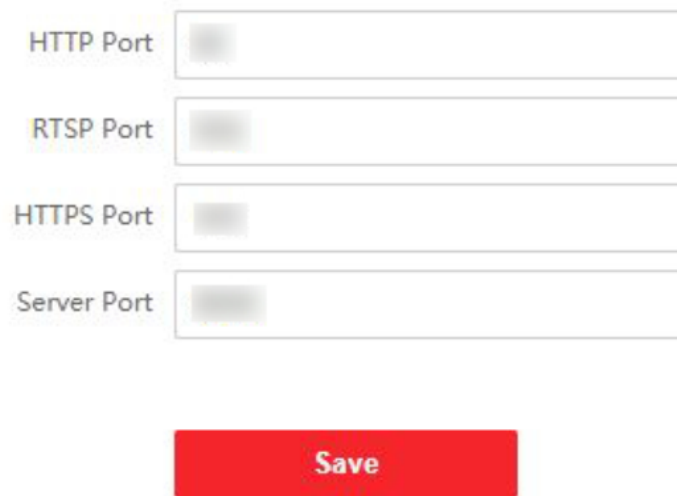

The screenshot shows a settings page with four input fields stacked vertically. Each field is labeled on the left: 'HTTP Port', 'RTSP Port', 'HTTPS Port', and 'Server Port'. The input fields are empty. Below the fields is a red rectangular button with the word 'Save' in white text.

**Figure 7-3 Port Settings**

2. Set the ports of the device.

**HTTP Port**

The default port number is 80, and it can be changed to any port No. which is not occupied.

**RTSP Port**

The default port number is 554.

**HTTPS Port**

The default port number is 443, and it can be changed to any port No. which is not occupied.

**Server Port**

The default server port number is 8000, and it can be changed to any port No. ranges from 2000 to 65535.

3. Click **Save** to enable the settings.

## SIP Setting

### Steps

1. Click **Network** → **Basic Settings** → **SIP** to enter the settings page.

Enable VOIP Gateway

Register User Name

Registration Password

Server Address

Server Port

Expiry Time  minute(s)

Register Status

Number

Display User Name

**Figure 7-4 SIP Settings**

2. Check **Enable VOIP Gateway**.
3. Configure the SIP parameters.
4. Click **Save** to enable the settings.

## FTP Settings

### Steps

1. Click **Network** → **Advanced** → **FTP** to enter the settings page.

Enable FTP

Server Type

Server IP Address

Port

Enable Anonymous

User Name

Password

Directory Structure

Parent Directory

Child Directory

**Picture Naming Rules**

Delimiter

Named Item

Named Element

Figure 7-5 FTP Settings

2. Check **Enable FTP**.
3. Select **Server Type**.
4. Input the **Server IP Address** and **Port**.
5. Configure the FTP Settings, and the user name and password are required for the server login.
6. Set the **Directory Structure**, **Parent Directory** and **Child Directory**.
7. Set the picture naming rules.
8. Click **Save** to enable the settings.

### Platform Access

#### Steps

1. Click **Network** → **Advanced** → **Platform Access** to enter the settings page.
  2. Select the **Platform Access Mode**.
- 



Guarding Vision is an application for mobile devices. With the App, you can view live image of the device, receive alarm notification and so on.

---

3. Check the checkbox of **Enable** to enable the function.
  4. **Optional:** Check the checkbox of **Custom** to custom the **Server Address**.
  5. Create a **Stream Encryption/Encryption Key** for the device.
- 



6 to 12 letters (a to z, A to Z) or numbers (0 to 9), case sensitive. You are recommended to use a combination of no less than 8 letters or numbers.

---

6. Click **Save** to enable the settings.

### 7.4.4 Video & Audio Settings

#### Video Parameters

##### Steps

1. Click **Video/Audio** → **Video** to enter the settings page.

Stream Type	Main Stream	▼
Video Type	Video&Audio	▼
Resolution	1280*720P	▼
Bitrate Type	Variable	▼
Video Quality	Medium	▼
Frame Rate	25	▼ fps
Max. Bitrate	2048	Kbps
Video Encoding	H.264	▼
I Frame Interval	50	

**Save**

Figure 7-6 Video Parameters

2. Select the **Stream Type**.
3. Configure the video parameters.

**Stream Type**

Select the stream type to main stream or sub stream.

**Video Type**

The video type is set as **Video&Audio** by default.

**Resolution**

Select the resolution of the video output.



**Note**

When the **Stream Type** is selected as **Sub-stream**, the **Resolution** is **640\*480p** by default.

---

**Bitrate Type**

Select the bitrate type as constant or variable.

**Video Quality**

When bitrate type is selected as Variable, 6 levels of video quality are selectable.

### **Frame Rate**

Set the frame rate. The frame rate is to describe the frequency at which the video stream is updated and it is measured by frames per second (fps). A higher frame rate is advantageous when there is movement in the video stream, as it maintains image quality throughout.

### **Max. Bitrate**

Set the max. bitrate from 32 to 16384 Kbps. The higher value corresponds to the higher video quality, but the better bandwidth is required.

### **Video Encoding**

The device supports H.264.

### **I Frame Interval**

Set I Frame Interval from 1 to 400.

4. Click **Save** to save the settings.

## **Audio Parameters**

### **Steps**

1. Click **Video/Audio** → **Audio** to enter the settings page.

Audio Channel

Stream Type  Main Stream  Sub-stream

Audio Encoding

Input Volume

Output Volume

Speak Volume

**Save**

**Figure 7-7 Audio Settings**

2. Configure the stream type and the audio encoding type.

**Audio Channel**

Select the audio channel to adjust the audio parameters.

**Stream Type**

Select the stream type to main stream or sub stream.

**Audio Encoding**

The device support G.711ulaw and G.711 alaw.

3. Adjust the **Input Volume**, **Output Volume** and **Speak Volume**.



**Note**

Available range of volume: 0 to 10.

4. Click **Save** to save the settings.
-

## 7.4.5 Image Settings

### Display Settings

Configure the image adjustment, backlight settings and other parameters in display settings.

#### Steps

1. Click **Image** → **Display Settings** to enter the display settings page.

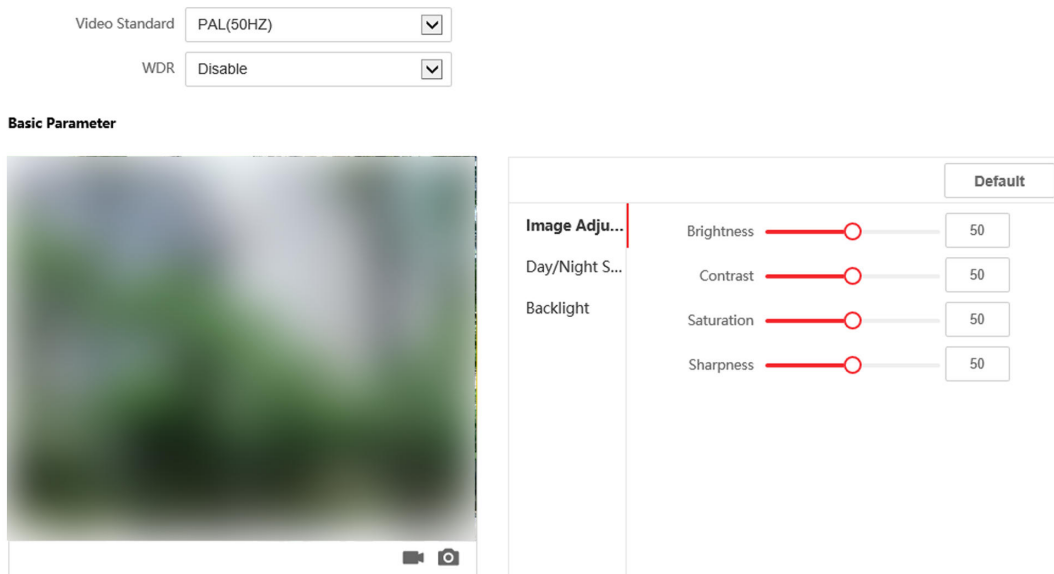

Figure 7-8 Display Settings

2. Select the **Video Standard**.
3. Select to enable or disable **WDR**.

---

#### **Note**

Wide Dynamic Range can be used when there is a high contrast of the bright area and the dark area of the scene.

---

4. Set the basic parameters.

#### **Brightness**

Brightness describes bright of the image, which ranges from 1 to 100.

#### **Contrast**

Contrast describes the contrast of the image, which ranges from 1 to 100.

#### **Saturation**

Saturation describes the colorfulness of the image color, which ranges from 1 to 100.

### Sharpness

Sharpness describes the edge contrast of the image, which ranges from 1 to 100.

#### 5. Set the **Day/Night Switch**.

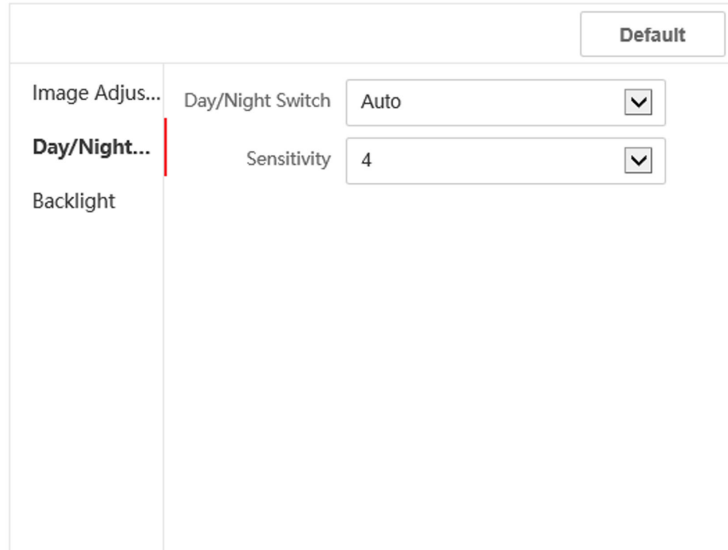

**Figure 7-9 Day/Night Switch**

- Set **Daytime** or **Night**.
- Set the mode as **Auto** and edit the sensitivity according to your needs.
- Set the mode as **Scheduled-Switch**. Set the start time and end time.

#### 6. Set the backlight parameters.

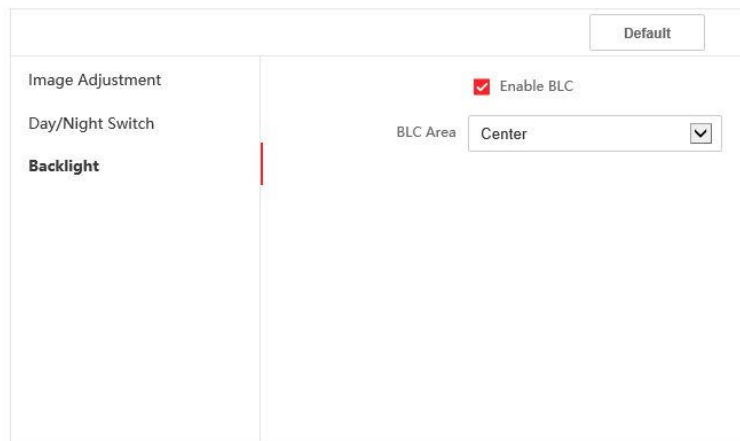

**Figure 7-10 Backlight**

- 1) Check to enable BLC.
- 2) Select **BLC Area**.

## OSD Settings

You can customize the camera name, time/date format on the live view.

### Steps

1. Click **Image** → **OSD** to enter the settings page.

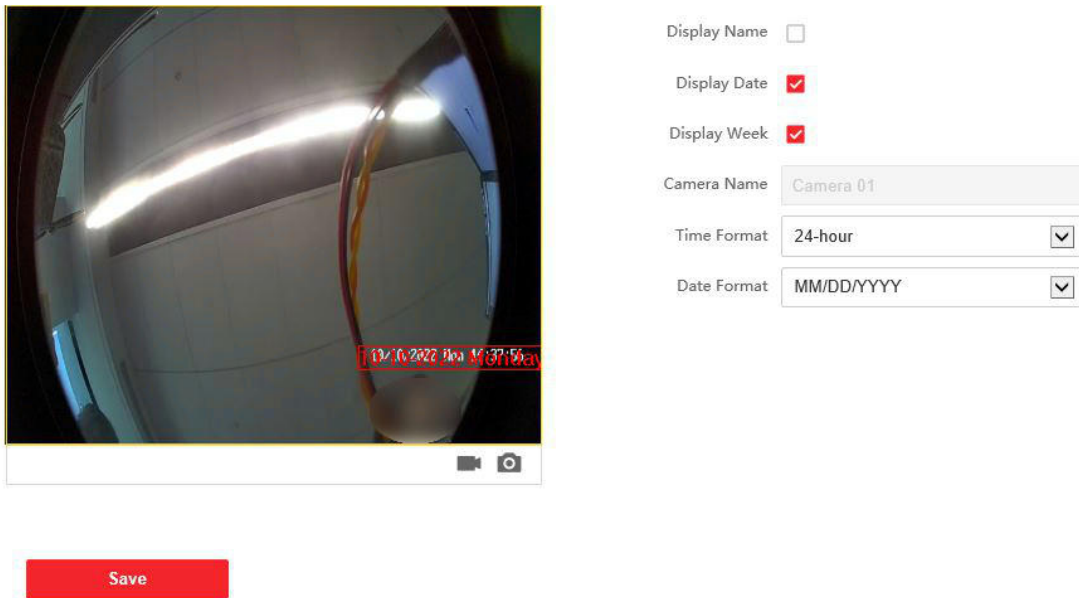

Figure 7-11 OSD

2. Check to enable **Display Name**, **Display Date** or **Display Week** at your actual needs.
3. Edit the **Camera Name**.

---



### Note

You can edit the camera name only when **Display Name** is enabled.

4. Select from the drop-down list to set the **Time Format** and **Date Format**.
5. Click **Save** to enable the settings.

## Target Cropping

### Steps

1. Click **Image** → **Crop** to enter the page.
2. Check **Enable Target Cropping** to enable the function.
3. Click  capture photo.
4. Click  start recording.
5. Select **Cropping Resolution**.
6. Click **Save**.



## Note

- You can select **Cropping Resolution** as **704\*576**, **1280\*720**, or **1920\*1080**.
  - You can zoom in or zoom out the image by selecting **Cropping Resolution** after clicking **Save**.
- 

## 7.4.6 Event Settings

### Motion Detection

Motion detection detects the moving objects in the configured security area, and a series of actions can be taken when the alarm is triggered.

#### Steps

1. Click **Event** → **Basic Event** → **Motion** to enter the settings page.

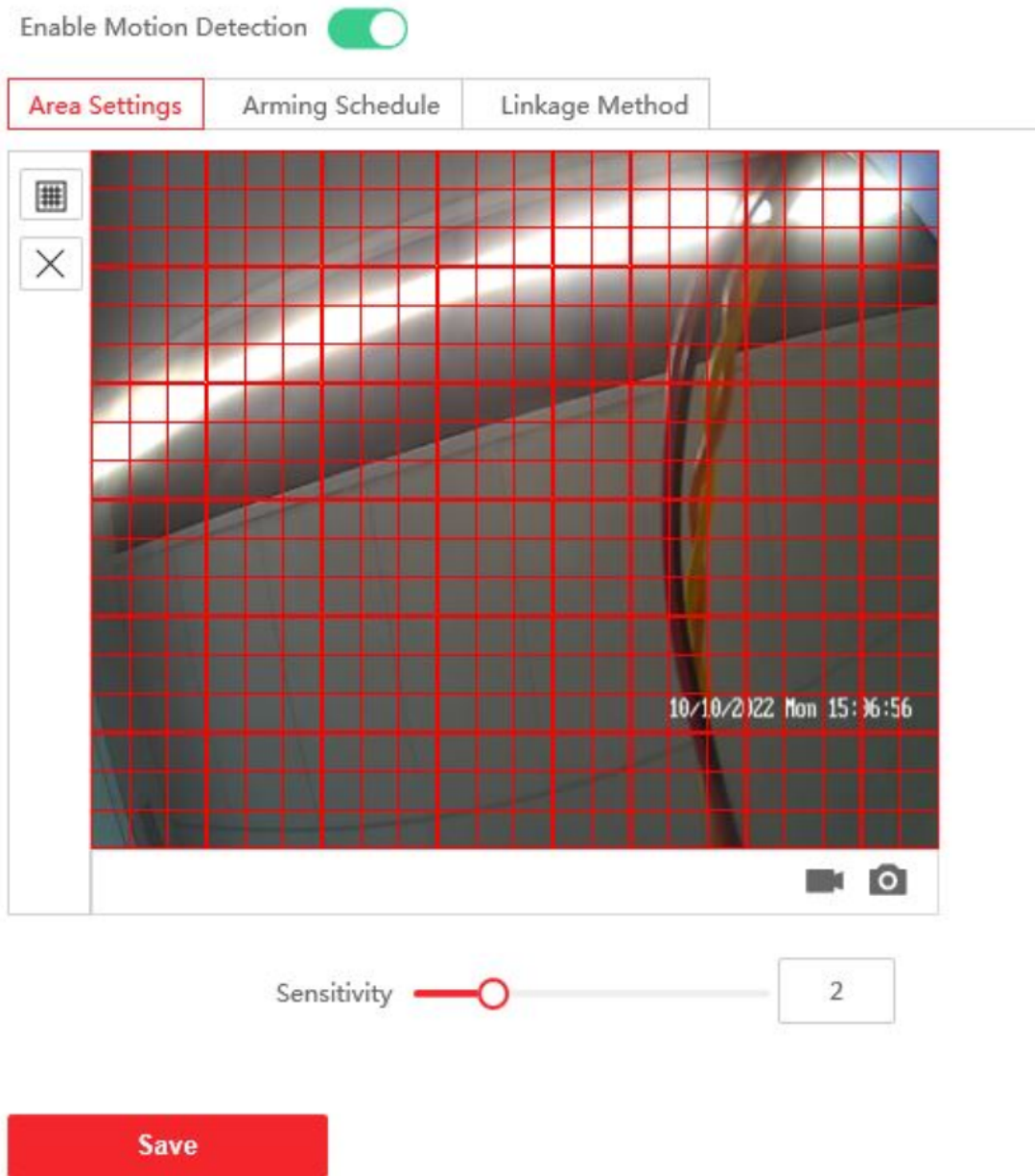

**Figure 7-12 Motion Detection**

2. Click to **Enable Motion Detection**.
3. Click **Draw Area**. Click and drag to draw a motion detection area.  
**Clear Area** Click **Clear All** to clear all of the areas.  
**Adjust Sensitivity** Move the slider to set the sensitivity of the detection.
4. Click **Arming Schedule** to edit the arming schedule.
5. Click on the time bar and drag to select the time period. Click **Save** to save the settings.

**Delete Schedule** Click **Delete** to delete the current arming schedule.

6. Click **Linkage Method** to enable the linkages.

### **Notify Security Center**

Send an exception or alarm signal to the remote management software when an event occurs.

7. Click **Save** to enable the settings.

## **Event Linkage**

### **Steps**

1. Click **Event** → **Basic Event** → **Event Linkage** to enter the settings page.

Major Type

Minor Type

**Normal Linkage**

Notify Surveillance Center

Figure 7-13 Event Linkage

2. Select the **Major Type** as **Device Event** or **Door Event**.
3. Select the **Minor Type**.
  - For device event, the **Minor Type** is set as **Tampering Alarm** by default.
  - For door event, select **Minor Type** as **Door Open Timed Out (Door Contact)**.
4. Select the type of the **Normal Linkage** for the event.
5. Click **Save** to enable the settings.

### 7.4.7 Intercom Settings

#### Device No. Configuration

Set the No. of the device, and linked devices can build a communication.

##### Steps

1. Click **Intercom** → **Device No.** to enter the settings page.
2. Select the device type from the drop-down list, and set the corresponding information.
3. Select the device type from the drop-down list, and set the corresponding information including **Floor No.**, **Door Station No.**, **Building No.**, **Community No.** and **Unit No.**



When you select **Doorphone** as **Device Type**, only **Community No.**, **Building No.** and **Unit No.** can be set.

4. Click **Save** to enable the device number configuration.



- For main door station (D series or V series), the serial No. is 0.
  - For sub door station (D series or V series), the serial No. cannot be 0. Serial No. ranges from 1 to 99.
  - For each villa or building, at least one main door station (D series or V series) should be configured, and one sub door stations (D series or V series) can be customized.
  - For one main door station (D series or V series), up to 8 sub door stations can be configured.
- 

#### Session Settings

##### Steps

1. Click **Intercom** → **Session Settings** to enter the settings page.

Registration Password

Main Station IP

Private Server IP

Enable Protocol 1.0

**Save**

**Figure 7-14 Session Settings**

2. Set **Registration Password**.
3. Set **Main Station IP** and **Private Server IP**.
4. Slide to enable Protocol 1.0.
5. Click **Save** to enable the settings.

## Call Settings

Go to **Intercom** → **Call Settings** to enter the page.

Configure **Max. Call Duration**, **Max. Message Duration** and **Max. Ring Duration**, and click **Save**.

---

### Note

- Max. call duration between the module indoor station and client ranges from 90 s to 120 s. The call will end automatically when the actual calling duration is longer than the configured one.
  - Max. message duration ranges from 30 s to 60 s. The message will end automatically when the actual message duration is longer than the configured one.
  - Max. ring duration ranges from 65 s to 255 s.
- 

## Ring-Back Tone Settings

Click **Intercom** → **Ringbacktone Settings** to enter the settings page.

Click **Add** to select the ring tone from PC.

---

### Note

Available Audio Format: WAV、AAC, Size: Less than 600 KB, Sample Rate: 8000Hz, Mono.

---

## Press Button to Call

### Steps

1. Click **Intercom** → **Press Button to Call** to enter the setting page.
  2. Check **Call Management Center** or **Call Specified Indoor Station** to set the button.
- 



If you check **Call Specified Indoor Station**, you should enter the specified indoor station No.

---

3. Click **Backlight Mode** and you can select a backlight mode from the drop-down list.

## I/O Settings

### Steps

1. Click **Intercom** → **I/O Settings** to enter the I/O input and output settings page.
  2. Select **I/O input No.**, **input mode**, **output No.**, and **output mode**.
  3. Click **Save** to enable the settings.
- 



- For door station, there are 4 I/O input terminals. By default, Terminal 1 and 2 correspond to Door Status. Terminal 3 and 4 correspond to interfaces of Door Switch.
  - For door station, there are 2 I/O Output Terminals. Terminal 1 and 2 correspond to Door interfaces (NO1/COM/NC1; NO2/COM/NC2) of door station. Door 1 is enabled by default. You can enable/disable IO Out according to needs.
- 

## Number Settings

Link the room No. and SIP numbers.

Click **Intercom** → **Number Settings** to enter the page.



**Figure 7-15 Number Settings**

Click **Add**, set the **Room No.** and SIP numbers in the pop-up dialog box.

## 7.4.8 Access Control Settings

### Door Parameters

Set the parameters of the door which is linked to the device.

#### Steps

1. Click **Access Control** → **Door Parameters** to enter the settings page.

Door No.

Name

Open Duration  s

Relay reverse  ON  Disable

**Figure 7-16 Door Parameters**

2. Select **Door No.**, and edit the **Name**.
3. Set **Open Duration**. When the time to open over the open duration you set, the door will be locked again.
4. Select **Relay Reverse** as **ON** or **Disable**.
5. Click **Save** to enable the settings.

## Appendix A. Appendix

### Installation Notice

While installing the door station, make sure that the distance between any two devices is far enough to avoid the howling and echo. The distance between two devices is recommended to be longer than 10 meters.

---

 **Note**

Devices mentioned here refer to indoor station, door station and master station.

---

### Wiring Cables

Cable	Specification
Power Cord of Door Station	RVV 2*1.0
Network Cable of Door Station	UTP- five Categories
Door Lock Wiring (with Door Contact)	RVV 4*1.0
Door Lock Wiring (without Door Contact)	RVV 2*1.0
Exit Button Wiring	RVV 2*0.5

